

Hubble



Landscape luminaires designed to provide directional spot light. The luminaires with connecting cable and bracket for permanent installations on a wall, under a ceiling or on a pillar or in landscape area. Spike mounting for the illumination of plants, building details and many other lighting tasks in interior and exterior lighting applications. Their sturdy construction makes them particularly suitable for areas where a high level of robustness is required.

Technical Specifications

- Luminaire made of die cast aluminium with non corrosive SS fasteners
- Clear tempered safety glass diffuser retained by die cast aluminium frame.
- EPDM gasket
- Mounting spike & bracket arrangement to facilitate easy installation at any desired location.
- Swivel range of the luminaire in the horizontal axis $+90^{\circ}/-20^{\circ}$
- Cable entries for through-wiring of mains supply cable.
- Luminaire supplied with GU5.3 holder.
- Safety class I
- Protection class IP 65
- CE - Conformity mark
- Suitable for operation on 240V, 50Hz single phase ac supply.

Product Benefits

- Sturdy construction in order to maintain performance of the luminaire and to reduce maintenance costs.
- Quick & simple installation.
- Clear glass in the front and rubber gasket to ensure adequate sealing against ingress of moisture, dust, insects etc.,

Area of Application

Pathways, Parks, Sculptures, Structures and Landscape lighting.

Available Finish

Pure polyester powder coated Black.



HUBBLE - BRACKET

HUBBLE - SPIKE

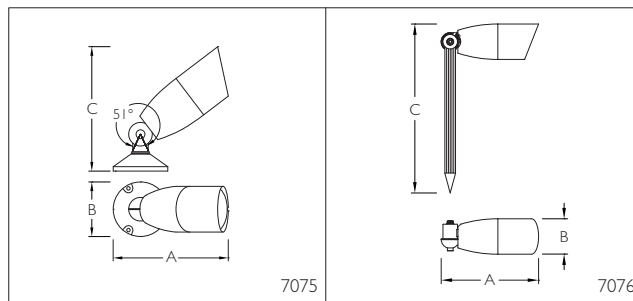

ID	Holder	A	B	C
7075	GU5.3	190	Ø75	170
7076	GU5.3	171	Ø62	296

The luminous flux and the connected wattage quoted might change as a result of technical progress. For the latest technical information, Installation guidelines and product updates with LED service life please refer to the website at www.klite.in



Important Note : To ensure proper installation, kindly translate / communicate the installation instructions to a qualified electrician in their respective local language.